

e-SolarMark +

High Speed Laser Marking and Coding systems!



Technical Specifications

Laser type	CO ₂ , Power class 10W to 55W
Marking Field	From 50x50mm /4x4in/ up to 400x400mm /16x16in/
Fonts	Multilanguage, including Unicode
Software	Job editor for Windows XP, Vista, 7, 8 Web interface for system configuration and control
User Interfaces	Multilanguage 15-inch touch screen with user friendly, intuitive interface for Preview, Edit & New jobs creation and System setup
Communication	RS232 / USB / Ethernet 10 Base T
Electrical requirements	115V / 230VAC, 50/60HZ, 1PH
I/O signals for installation	Shaft encoder, NPN/PNP Product detector inputs Remote Interlock, Key switch, Safety shutter control Fume extractor, Compressed air control System ready, Marking, Fault outputs 15 configurable user Inputs & Outputs
Cooling	Integrated air cooling with dust protection
Ambient temperature	10-40°C / 50-104°F, Suggested 15-30°C / 69-86°F
Humidity	up to 90%, non-condensing
Safety	class 4, according to EN 60825-1 class 4 ready, according to ISO 13849
Weight	Control unit 10kg / 22lb / 14kg / 31lb / Marking unit 15kg / 33lb / 25kg / 55lb /

Dimensions

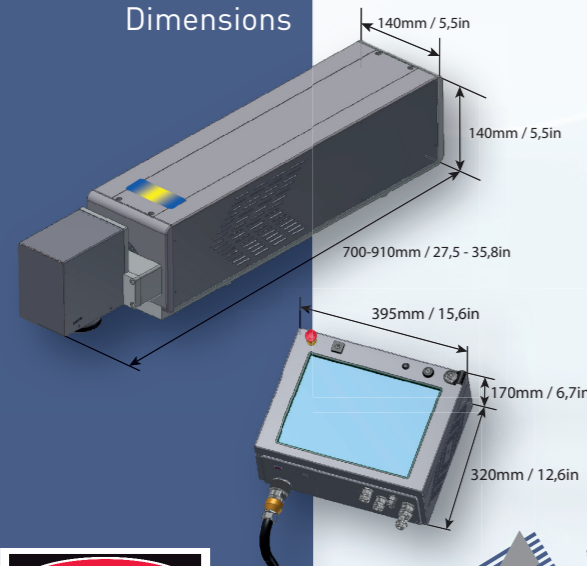

OPTIONAL CONFIGURATION

- water cooling
- compressed air cooling
- straight head laser beam output
- flexible beam delivery system
- remote preventive diagnostics
- conduit length extension
- red laser print position preview
- 19-inch control unit cabinet

Specifications are subject to change without notice as products are continually improved.
CE and CDRH compliant



For more
PRESA NV, Brusselsesteenweg 558,
3090 Overijse, Belgium
Tel.: +32 2 657 02 22
E-mail: marketing@presa.com
Web: www.presatendeur.eu



e-SolarMark +

High Speed Laser Marking and Coding systems!

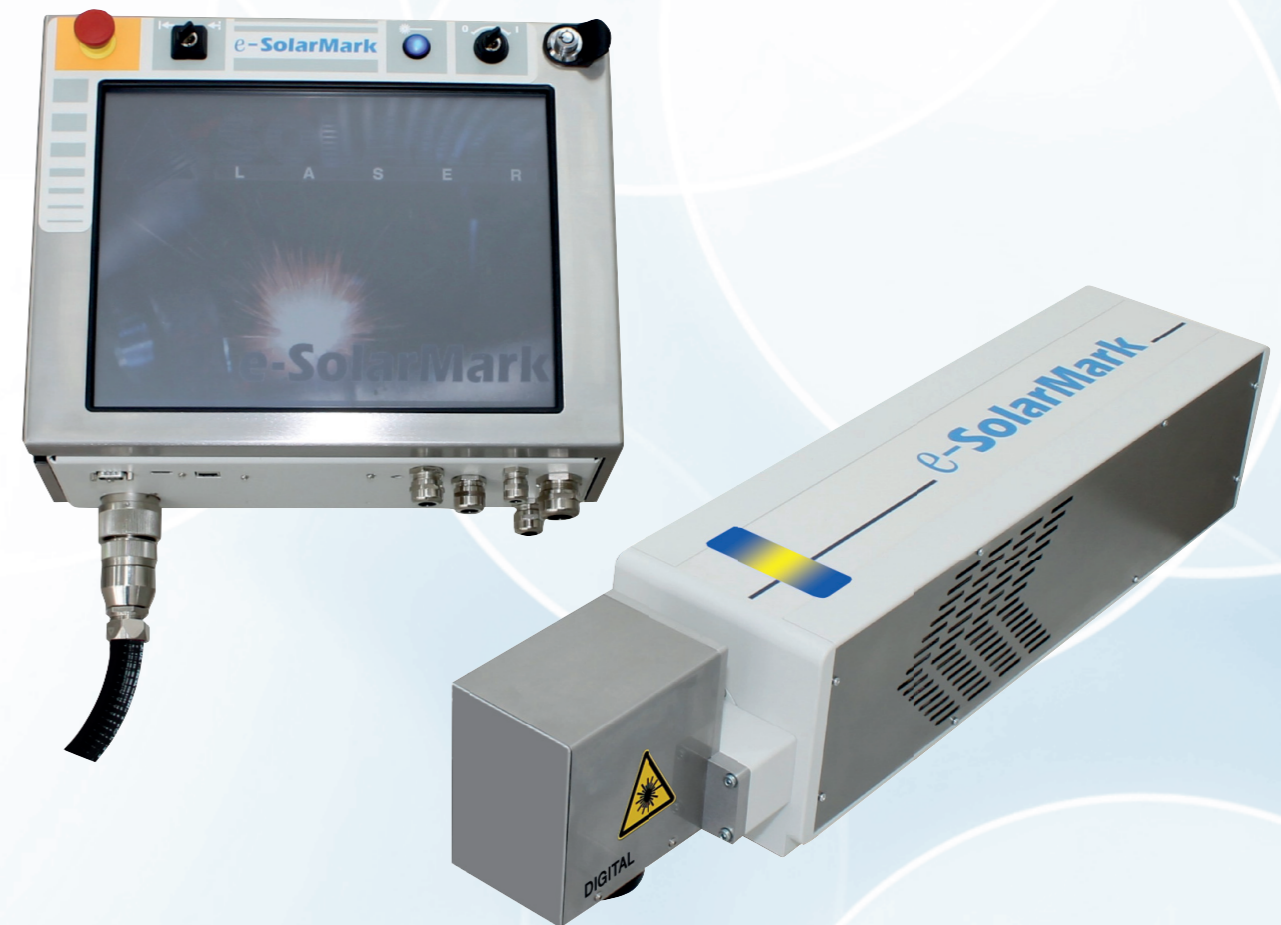

The latest generation of well known vector marking and coding e-SolarMark systems from Solaris

e-SolarMark +

High Speed Laser Marking and Coding systems ...

... for all packaging and industrial sectors!

e-SolarMark+ is the Latest Generation of vector marking and coding systems

A high speed and quality solution for permanent laser codes of alphanumeric texts / dates / timers, serial numbers, barcodes, 2D codes and graphics on products and packages.

An ideal tool for a wide range of materials and production line speeds for packaging and industrial sectors.

Designed and manufactured by Solaris Laser, industry leader in high quality laser systems for over 20 years.

e-SolarMark+ is Easy to Run

The innovative Solaris Laser interface makes it possible to operate the system with new user friendly 15-inch touch screen control panel or remotely from anywhere.

Multilanguage quick steps software allows easy operator access to preview and edit functions. Intuitive installation wizard helps in fast machine set up.

System designed for easy implementation into new or existing production lines. Compact size makes the system convenient and safe to install.

e-SolarMark+ is Flexible

With a choice of control panel versions, different laser power sources and printing areas, e-SolarMark+ offers the right configuration for various market demands.

Solaris Laser beam delivery systems allows for easy installation on the most limited spaces of production lines.

I/O signals enables control and diagnose the system remotely, to local production line supervisors or external web servers.

Multiple printing heads can now be operated under one master control panel.

e-SolarMark+ offers Great Performance

The e-SolarMark+ includes a very powerful Solaris Laser high speed scanning head technology. With optimised optical parameters and superb software performance, the system is the fastest in its class, up to 40% faster than market standards.

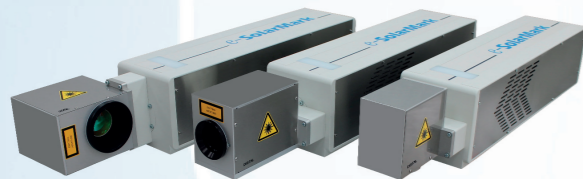

... Food

e-SolarMark+ delivers an excellent laser coding solution to wide variety of food products packages, such as confectionery, snack foods, dairy, frozen and dried process foods. Applied also for perforation on flexible packaging materials.



... Beverage

e-SolarMark+ is designed to code on PET, glass, paper labels and carton boxes, at low to high production line speeds. Ideal solution for water, wine, spirits and soft drink manufacturers.



... Tobacco

Reliable performance, together with small size and simplicity of integration, make the e-SolarMark+ ideal solution for demanding coding on tobacco packages. e-SolarMark+ meets the demand whether coding on single or bundle packs, with content of multilanguage texts, numbers or 2D datamatrix.



... Cosmetic/Beauty

Laser printing with e-SolarMark+ complements the highest standards of product design. Laser coding is the ideal solution for identification on labels, tubes, bottles, cartons and other materials used in cosmetic package sector.

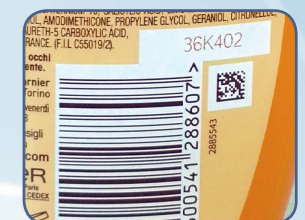

... Pharmaceutical

e-SolarMark+ produces multiple lines of print in any orientation, with 2D data matrix codes, on blisters, cartons, labels and bottles. e-SolarMark+ provides the right software solution for pharmaceutical standards.



... Industrial

e-SolarMark+ offers flexibility of integration, with high quality marks for automotive, electronics, construction, wood working and other industrial sectors, and are compliant with ISO 13849 for the highest safety standards.

